

# 1250 Air Bar

## Static Eliminator

*The 1250 Air Bar uses low pressure compressed air to extend the effective static neutralisation range to over 500mm.*

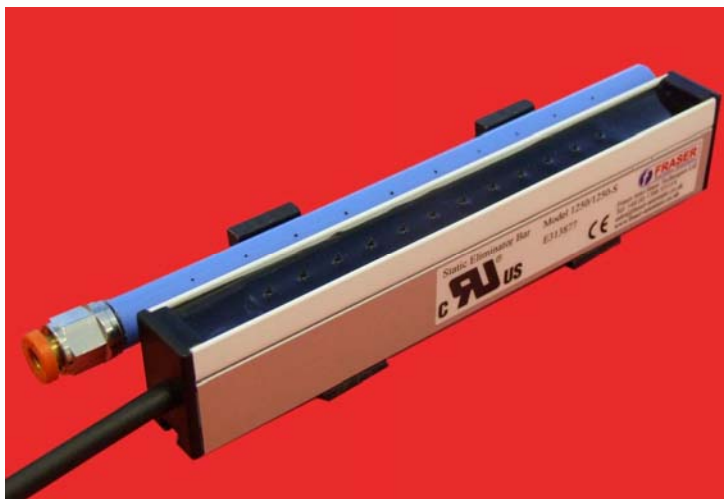

### Benefits and Advantages

- The 1250-Air Bar has all the advantages of the 1250-S Bar with the assistance of an airflow which extends the neutralisation distance to over 500mm.
- It is used for blowing ionised air into a restricted area, onto a product which moves in position or onto a substantially 3-dimensional product.
- Typical applications for the 1250-Air Bar are stopping film sticking to rollers on packaging machines, neutralising the static charge on vacuum- and thermoformed packaging, keeping sensors clean and free of static, neutralising mouldings on conveyors and many others.
- While the primary use of the 1250 Air Bar is to produce a gentle flow of ionised air at a low air pressure, it can also be used for higher pressure cleaning applications, if the air fittings are suitable - contact factory for details.

### How it Works

Ionised air from a standard AC static eliminator has a limited life - typically about 2 seconds - before it recombines to become ordinary air. This time scale limits the range of static eliminator bars - for example, the maximum range of the standard 1250-S Bar is 150mm.

The 1250 Air Bar uses a flow of compressed air to transport the ions to the static charge within 2 seconds.

The air travels across the Bar at 45°. The positioning and installation must take this into account

Air travels at 45° across the static eliminator bar picking up the ionisation and transporting it to the target.



## Air Supply:

The compressed air should be clean and dry. The pressure required depends on the length of the Bar. A typical pressure to achieve an airflow of 2m/sec on a 500mm long 1250 Air Bar is 0.8 Bar.

The holes in the air pipe are 1mm, spaced 15mm apart. The air consumption will depend on the length of the bar and the pressure of the compressed air. The 500mm Bar mentioned above will use approx 40 lit/min at 0.8 Bar.

The standard air fitting supplied on the 1250 Air Bar depend on its length:

- 1250 Air Bar length - up to 1000mm: one 10mm push-in air fitting
- over 1000mm: one 10mm push-in air fitting at each end.

Other air fittings may be specified at time of ordering.

## Air Pressure:

The normal operating air pressure is 0.5 - 2 Bar, depending on the length of the Bar. The maximum air pressure is 7 Bar provided that air fittings for that pressure are specified - please check with factory.

## Construction:

1250-S Bar - see dedicated Datasheet

Pipeholders: Nylon brackets, M4 socket screws hold the pipe into the brackets.

Fixing Studs: M4 x 25mm

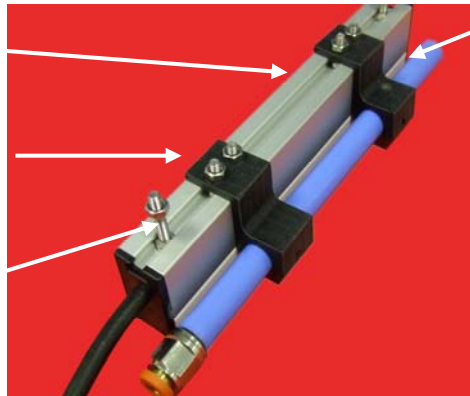

Airpipe: standard pipe is 12mm PVC with 1mm air holes every 15mm.

Other materials and hole arrangements are available, as agreed with factory.

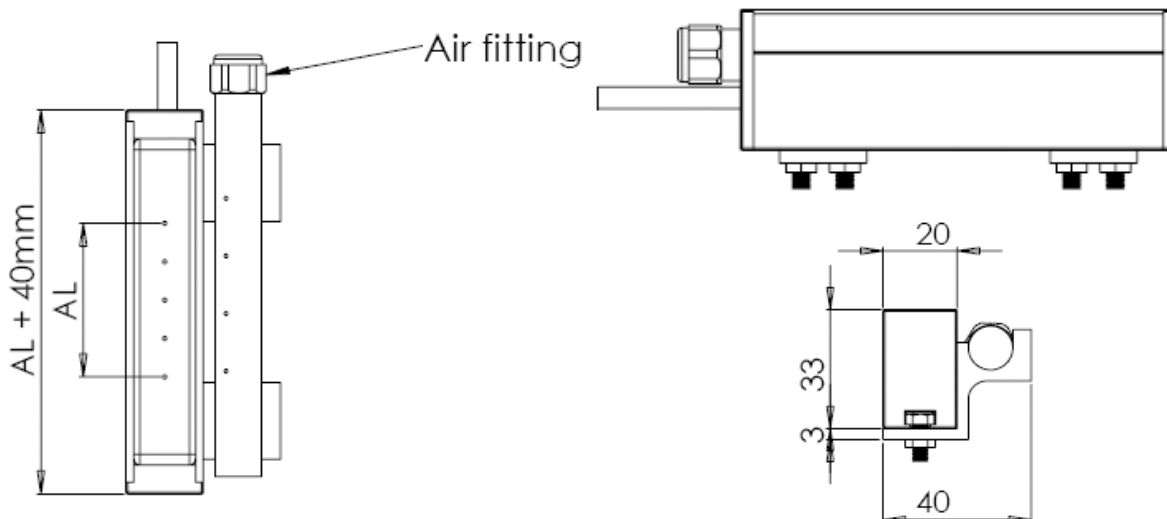

1250-Air Bars are CE Certified