

ANTI-STATIC BARS

1250 & 1250-S STATIC ELIMINATORS

Powerful performance and market-leading reliability make the 1250 and 1250-S the first choice static eliminators for manufacturers.

The 1250 and 1250-S neutralise static electricity on sheet, web and similar processes throughout the plastics, packaging, converting and related industries.

- > The modern design gives high performance and completely shockless operation.
- > Stay-sharp etched emitters for better long term performance.
- > Emitters at 10 mm pitch provide the most intense field of static neutralisation.
- > All electronic components are fully encapsulated for maximum reliability.
- > They are suitable for food, medical, pharmaceutical and many cleanroom applications.
- > Robust construction ensures a long life of high performance.
- > Simple to install - with fixed mounting studs (1250) or studs sliding in slot (1250-S).
- > Operating distances of up to 150 mm, best distance 20 - 50 mm.
- > Washable and easy to clean.

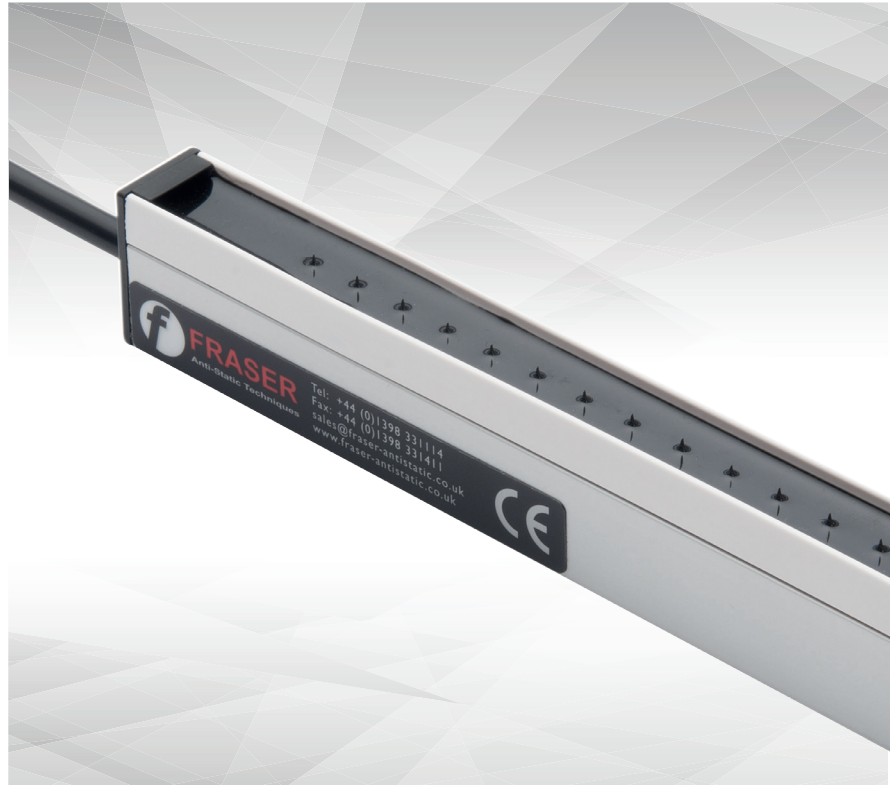

Specification

Length:	From 60 mm to 6000 mm.
Construction:	Anodised aluminium, epoxy resin, ABS and hardened etched emitters.
Cable:	Hi-Flex 30 kV screened cable with 70 mm bend radius. Standard length is 2 m - longer lengths can be specified at time of order (subject to maximum load on power unit),. 90° cable exit option. Bars may also be supplied in series- joined by cable. Also available with detachable cable- see datasheet for Model 1255.
Safety:	5 mA maximum current from Power Unit. High voltage resistance inside bars further limits current below 50 μ A.
Protection Classification:	IP66. Fully sealed.
Environment:	60° maximum temperature. 70% rH non-condensing max.
Power Units:	Use with Fraser 5.5 kV and 6 kV Power Units. See Datasheets.
Standards:	CE. UL (US and C) Listing is a free of charge option.

How it works

The 1250 works by applying high voltage to an emitter in a controlled and safe way. The electric field around the emitters ionises the air - breaking it up into positive and negative ions. These ions neutralise static electricity by being attracted to charges of the opposite polarity. Unused ions quickly dissipate into the atmosphere.

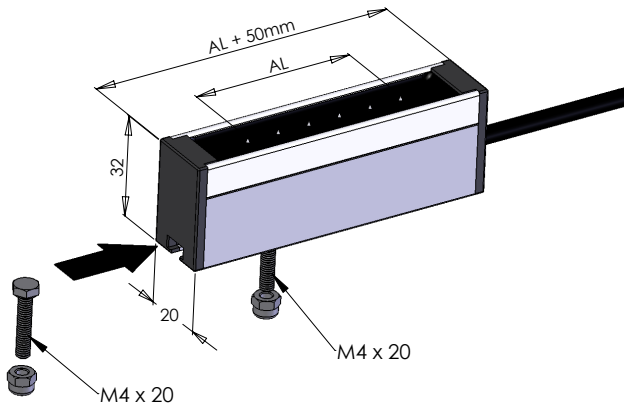

1250-S

The 1250-S has M4 x 20 mm hexagon head mounting studs which slide in a groove on the underside of the bar. This gives fast and simple installation.

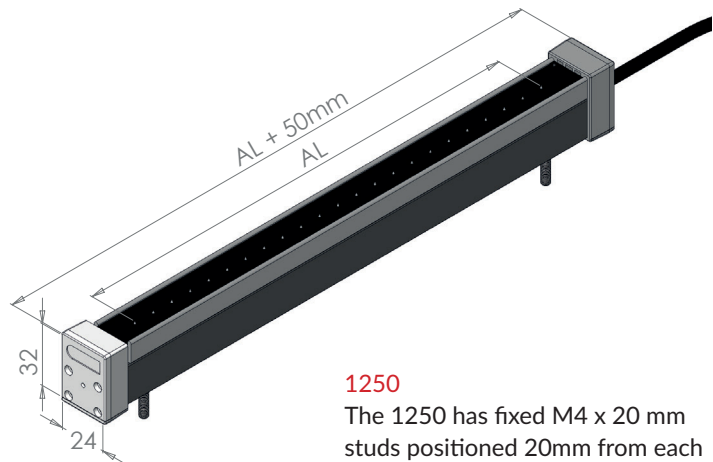

1250

The 1250 has fixed M4 x 20 mm studs positioned 20mm from each end, and in the middle for longer bars.

Variants

- EX - ATEX:** For hazardous areas see EX-1250 datasheet.
- Airboost:** For extending the range up to 500mm, see 1250-AB and 1250 Air Datasheets.
- Balanced:** For high tech applications where an accurate electrical ion balance is required.
- Combination:** A passive static discharger may be combined with a 1250, for speeds over 1000 m/min.
- Series:** Bars supplied in series - joined by cable.
- Detachable Cable:** See 1255 Datasheet.